



G2 GOOSENECK HITCH ASSEMBLY

Instruction Manual



You will find the most up to date version of this document on our website
www.tiddtech.com/resource-center/tidd-tech-manuals

1100 Roundhouse Road • Spooner, WI 54801
Toll Free: 1-877-843-3832 • Local: 1-715-635-3220
Website: www.tiddtech.com • Email: ttech@tiddtech.com

Packing List

G2 Gooseneck Hitch Assembly

- (1) Main Gooseneck Hitch Body (“L” shaped piece)
- (2) Tidd Tech decals; one centered on each side of the horizontal tubing

- (1) Jack Plate (flat plate with 4 holes)
- (4) 3/8” x 3-1/4” HB + LN connecting plate to main body

- (1) Channel Stiffener
- (2) 1/2” x 3-1/4” HB, FW + LN, connecting stiffener to back of hitch plate; bolt heads against channel; washers and lug nut against SST face

- (1) 1-7/8” Coupler Assembly with locking mechanism in place
- (1) 1/2” x 2-3/4” HB (installed)

- (2) Brace Assemblies (right and left)
- (2) 3/8” x 2” square U-bolts + LN inserted into base plate holes
- (2) 3/8” x 3” HB + LN inserted into one set of top plate holes

- (1) Tube Jack (3000 lb. side wind, bracketless)
- (1) Corrugated box 36x5x24

To start, use a piece of wood or some other prop to hold your unhitched G2 up off the ground so that its frame is parallel to the ground.

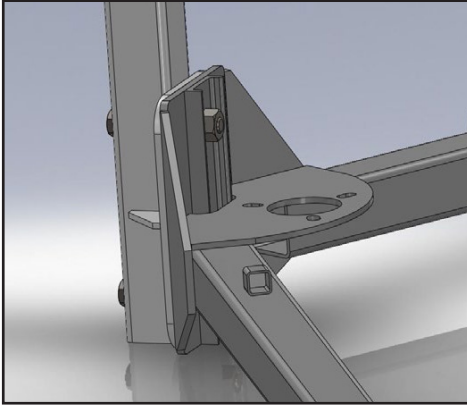

Remove your old hitch from the front of the G2. Assemble the main “L” shaped part of the Gooseneck Hitch, channel backing plate, (2) 1/2” x 3-1/2” hex bolts and (2) 1/2” lock nuts as shown in the picture, and tighten securely.

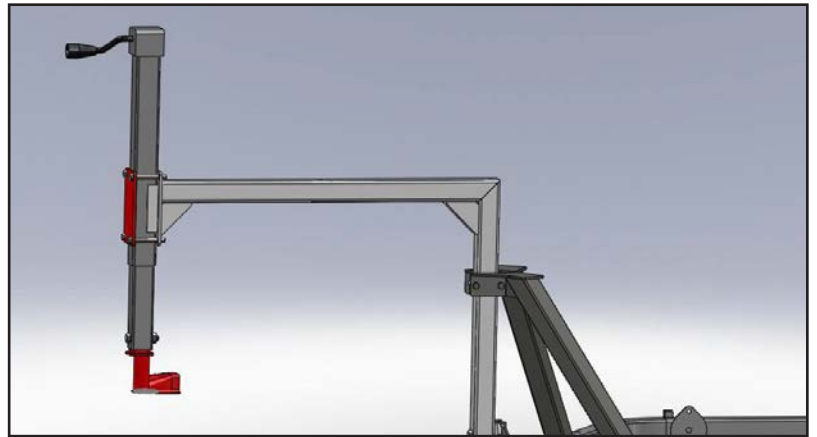

Use the (4) 3/8” x 3-1/4” hex bolts and locknuts to loosely fasten the Jack Plate to its mate at the top end of the main hitch body. Slide the tube jack down between the two plates so that the bottom end of the jack exterior tube is about two inches below the bottom of the plates. Make sure that the jack is oriented so that the jack handle is forward towards the snow mobile. Tighten fasteners just enough to hold the jack temporarily in place. The 1/2” x 2-3/4” hex bolt will allow you to attach the hitch coupler to the bottom of the jack.

Find the (2) 3/8” x 2” U-bolts and locknuts to loosely attach the bottom of the right and left braces to the G2 front frame. The (2) 3/8” x 3” hex bolts are used to bolt the top of the braces together and secure them to the main gooseneck frame. Tighten these top fasteners first and then the U-bolts.

Back your snowmobile up so that the hitch ball is below the coupler. Adjust the jack between the mounting plates so that the coupler sits two or three inches above your ball. Secure all fasteners sandwiching the jack between the jack plates. Use the jack crank to lower the coupler over the ball and engage the locking mechanism to hold the coupler in place. If you have everything properly adjusted, the front frame of the G2 should be parallel to your trail surface. Remember, these final adjustments should be done with someone sitting on the snowmobile to mimic a grooming scenario.

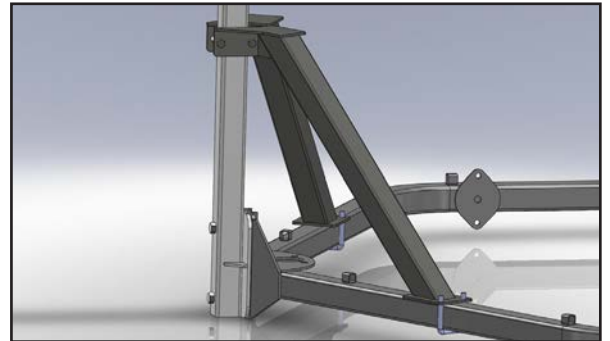

TIPS FOR USING THE G2 GOOSENECK HITCH

1. Use the toothbar and actuator to hitch and unhitch. Run the toothbar all the way down (with a 6” wood block under each end) to take the weight off the hitch. Release the coupler lock and wind the hitch all the way up. Now you can maneuver your snow machine.

2. When you get stuck, do the same as above – you can raise the toothbar all the way up and stomp loose snow with your boot under the raised toothbar. Now, if you lower the toothbar it will raise the machine upwards, taking the weight off the hitch. You can unhitch and move the snow machine back to firm trail surface and then back up to within reach (a sharp angle is fine). Pivot the G2 by pulling on the gooseneck hitch to swing it over to where you can re-hitch to the snow machine. Just remember once you are re-hitched to raise the toothbar before you attempt to pull away!

3. Experiment with how far you can jack-knife your G2 and snow machine with the GN hitch. We have found it very easy to turn completely around on a 10’ wide trail by simply pulling over to the far side, backing up (while turning) until reaching “maximum jack-knife” and then pulling forward pointing the opposite direction. This will leave snow machine marks on the trail, but in many cases that is not a problem.

More Information

Stay tuned to our website, www.tiddtech.com, for updates and information specific to using the G2, and XC trail grooming in general. Please let us know when you discover something that you think other trail groomers would appreciate knowing. We like your feedback!

LIMITED WARRANTY FOR TIDD TECH PRODUCTS BY TIDD TECH

Products from Tidd Tech carry a one year warranty. If the equipment fails due to a defect in materials or workmanship within one year from the date of purchase, Tidd Tech will repair or replace the part free of charge.

This warranty is not transferable and does not cover damage resulting from anything other than defects in material or workmanship. This warranty does not cover damage caused by unreasonable use, nor replacement of non-defective parts that may wear and need to be replaced within the warranty period.

For warranty service you must, at your own expense, arrange to deliver or ship the product or part(s) for warranty repairs to Tidd Tech at the address below.

This limited warranty is in lieu of all other express warranties. Tidd Tech shall not be liable for any special, incidental or consequential damages.

This warranty gives you specific legal rights, and you may also have other rights which vary from state to state.

TIDD TECH

1100 Roundhouse Road • Spooner, WI 54801

Phone: 1-877-843-3832

Email: ttech@tiddtech.com

www.tiddtech.com